



Sailing Instructions

Authority

The Plymouth Yacht Club Junior Regatta is organized under the authority of the Plymouth Yacht Club Sailing Committee and will be governed by the Rules as defined in The Racing Rules of Sailing, the prescriptions of U.S Sailing, USODA. Class Rules, Club 420 Class Rules, Optimist Class Rules, Sailing Instructions, and any other applicable rules.

Entries

International Optimist Dinghy: Championship Line (White, Blue & Red Fleets)
Green Fleet (Novice Optimist Sailors Only)
Club 420

Limitations

For 420s, all competitors (skippers and crew) shall not have reached their 19th birthday during the 2024 calendar year.

For Optimists, all competitors shall not have reached their 16th birthday during the 2024 calendar year.

Notices

Notices to competitors will be posted on the official noticeboard located at the PYC Junior Club House.

Signals

Signals made ashore will be displayed from the flagpole located adjacent to the PYC launch dock. If a postponement is signaled ashore, the warning signal will be made not less than 30 minutes after AP is lowered.

Schedule

SUNDAY, JULY 21ST

4:00 pm Boats and trailers arrive in parking lot

MONDAY, JULY 22ND

8:00-9:30 Onsite Check-In/Breakfast Buffet

9:30 Competitors' Meeting

10:00 Harbor Start

10:30 First Warning Gun

Snacks/Sandwiches/Water

2:00 Last Warning Signal

3:30 Cookout with entertainment

TUESDAY JULY 23RD

9:30-10:30 Breakfast Buffet

10:30 Harbor Start

11:00 First Warning Gun

Snacks/Water

1:30 Last Warning Signal

3:00 Pizza & Ice Cream, Awards Ceremony

Scoring

The Low-Point Scoring System, RRS Appendix A2 will apply. One race is required to be completed to constitute a series. There will be no maximum number of races. One throw out will be allowed after five races are completed.

Prizes

Awards for the first three places in each fleet as well as an overall award for Opti Championship Fleet. Green Fleet competitors will receive participation awards.

Coach boats

All visiting coach and support boats are required to check in before heading out onto the water. Boats can be launched at the Club or the town boat ramp at the head of the harbor. Each coach boat shall have a working VHF radio, an anchor, and a basic first aid kit. No coaching is allowed after the first gun for each race (except for Green Fleet competitors in the bottom half of any given race).

VHF

Opti Green Fleet Race Committee will be monitoring **Channel 68**.

Opti Champ Fleet Race Committee will be monitoring **Channel 69**.

420 Fleet Race Committee will be monitoring **Channel 71**.

Racing Area

The Optimist fleets will start in open area EAST of the PYC Docks. The first starting area will be the Green Fleet, closest to the Club, and the second starting area will be the Championship Fleet, closest to Plymouth Long Beach. The Club 420s will start in the area NORTH of Plymouth Harbor breakwater and SOUTH of the Plymouth Harbor Channel marker "12". Getting to this location requires crossing the Plymouth Harbor Channel which often has heavy commercial and recreational traffic. Competitors will cross the channel from buoy markers C "21" and N "22" and must follow directions that may be given by the Plymouth Harbor Master or Safety Boats designated for this purpose.

Courses

The courses will be Modified Windward/ Leeward (WL), a Modified Triangle (T), or an Olympic Triangle/Windward/ Leeward (TWL). The course will be designated by black letters written on a whiteboard on the RC start boat.

All rounding marks will be orange or yellow inflatable buoys. Diagrams show the courses, course designations, the marks in order. The rounding direction of each mark will be provided to all competitors.

Lines

All starting and finishing lines will be between the orange flag on the RC starting vessel and the pin mark.

The Club 420 fleet will be started using Rule 26. The Optimist Championship and Green fleets will start by using rule 3-minute sound signals as found in Appendix "Q" of the RRS.

Time Limit

The time limit for each race will be 1 hour for first boat to finish. Boats finishing more than 30 minutes after the first boat that sails the course finishes will be scored TLE (Time Limit Expired) without a hearing. This changes RRS 35, 63.1, A4 and A5.

Protests

Protest shall be delivered to the RC table inside the PYC Junior Clubhouse within 30 minutes after the race committee boat docks. The protest time limit and a list of protest received will be posted on the notice board. Hearings will be held as soon as possible after racing in the Junior Clubhouse.

Other

Snacks/Sandwiches & Water will be provided to competitors on the water Day 1. A Cookout will be provided to all participating sailors, coaches and parents after racing on Day 1 with live entertainment. Snacks & Water will be provided on the water Day 2. Pizza and Ice Cream will be provided on Day 2 followed by the Awards Ceremony.

The Club's facilities will be available.

Contact

Wendy Reifeiss, Regatta Chair

email: wendyreifeiss@gmail.com

cell: 508-320-3146

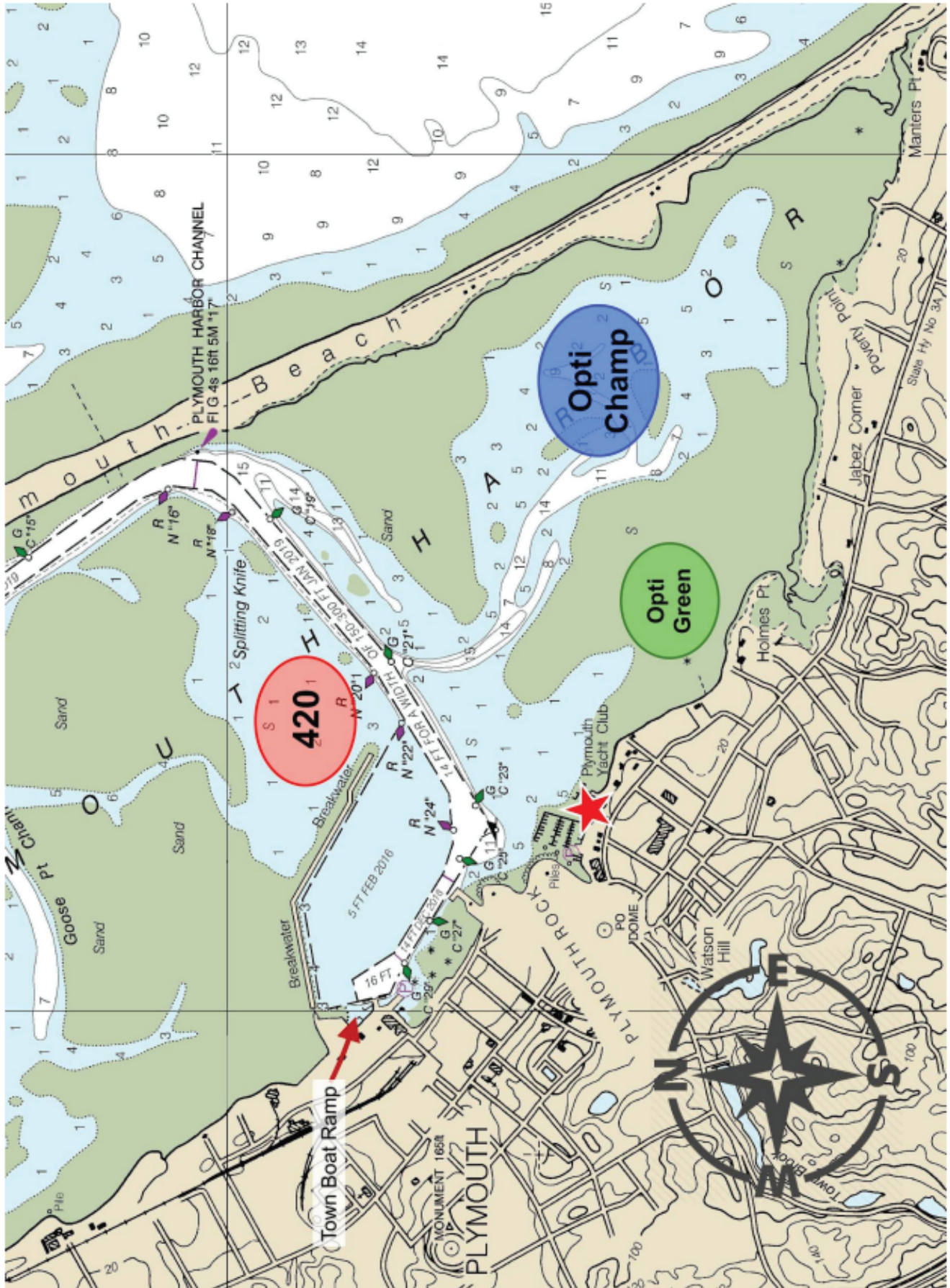



Race Course Diagrams

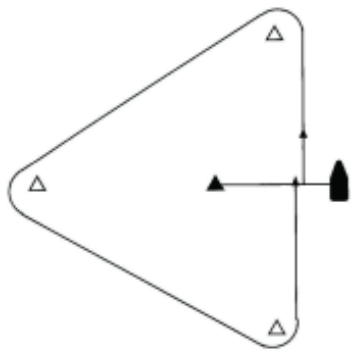

Triangle



Windward/Leeward

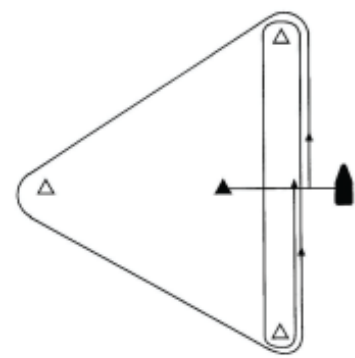

Olympic

Preparatory Signals



↑ ● ↓ —

P Preparatory signal.



↑ ● ↓ —

I Rule 30.1 is in effect.



↑ ● ↓ —

Z Rule 30.2 is in effect.



↑ ● ↓ —

Black flag. Rule 30.3 is in effect.

Recall Signals



↑ ●

X Individual recall.



↑ ● ● ↓ ●

First Substitute General recall. The warning signal will be made 1 minute after removal.

Shortened Course



↑ ● ●

S The course has been shortened. Rule 32.2 is in effect.

Other Signals



↑ ●

L Ashore: A notice to competitors has been posted. Afloat: Come within hail or follow this boat.



— — — —

M The object displaying this signal replaces a missing *mark*.



↑ ●

Y Wear a personal flotation device.



(no sound)

Blue flag or shape. This race committee boat is in position at the finishing line.