



56th ANNUAL COMODORO MANUEL RASCO SNIPE REGATTA February 1-2, 2025

Organizing Authority (OA): Coconut Grove Sailing Club (CGSC) and Snipe Fleet #7
Miami, FL, USA



SAILING INSTRUCTIONS Posted 1/24/25; Amended 2/1/25

In the notice of race (NoR) or sailing instructions (SIs) for this event the following notations apply:

- [DP] means the penalty for a breach of that rule may, at the discretion of the protest committee, be less than disqualification.
- [NP] means a boat may not protest another boat for breaking that rule or request redress based on that rule. This changes RRS 60.1(a) and 62.1(a).
- [SP] means for a breach of this rule a standard penalty will be applied by the race committee without a hearing. This changes RRS A5.1.

1 RULES

- 1.1 The event is governed by the *rules* as defined in *The Racing Rules of Sailing*.
- 1.2 The following additional documents govern the event:
 - (a) SCIRA By-Laws (https://www.snipe.org/images/2019/2019_Bylaws_final.pdf)
 - (b) Rules of Conduct for Sanctioned or Club/Fleet Regattas (ROC) (https://www.snipe.org/images/2017/2018/SCIRA-2018-roc_nochampionship-final.pdf)
- 1.3 The following Prescriptions of US Sailing are the only Prescriptions that will apply: Appendix R, the prescription to the preamble to Part 5, and the prescriptions to rules 65.1, 70.3(b), 76.1 and 88.2
- 1.4 In case of conflict between the NoR and the SIs, the SIs shall prevail. This changes RRS 63.5(c).
- 1.5 In case of conflict between the ROC and either the NoR or SI, the SI shall prevail.
- 1.6 If there is a conflict between languages the English text will take precedence.

2 CHANGES TO SAILING INSTRUCTIONS

- 2.1 Any change to the SIs will be posted no later than 150 minutes before the scheduled warning on the day it will take effect, except that any change to the schedule of races will be posted by 1900 on the day before it will take effect.
- 2.2 Oral changes to the SI may be given on the water. The race committee signal vessel will display flag L and announce via megaphone in accordance with RRS 90.2(c). Competitors may also approach the signal vessel and verbally receive the change or read it from a whiteboard while flag L is displayed.

3 COMMUNICATIONS WITH COMPETITORS

- 3.1 Notices to competitors will be posted on the official notice board located online at: https://www.regattanetwork.com/event/28576#_newsroom.
- 3.2 A competitors' briefing will be held at CGSC Saturday morning at 0900.
- 3.3 On the water, the race committee intends to monitor and communicate with support persons on VHF radio channel 73.
- 3.4 [DP] While racing, except in an emergency, a boat shall not make voice or data transmissions and shall not receive voice or data communication that is not available to all boats.

4 SIGNALS MADE ASHORE

- 4.1 Signals made ashore will be displayed at the CGSC flag hoist. Notification of signals made ashore will also be posted on the notice board.
- 4.2 When flag AP is displayed ashore, '1 minute' is replaced with 'not less than 60 minutes' in Race Signals AP.

5 SCHEDULE OF RACES

- 5.1 Five (5) races are scheduled to be sailed. No more than three (3) races will be sailed on one day.
- 5.2 The scheduled time of the warning signal for the first race is 1200 on Saturday and 1000 on Sunday.

5.3 [NP] To alert boats that a race will begin soon, a series of sounds will be made (1) minute prior to the warning signal.

5.4 No warning signal will be made after 1430 on Sunday.

6 CLASS FLAGS

6.1 The class flag is a white flag with the Snipe insignia/emblem.

7 RACING AREA

7.1 The racing area will be on Biscayne Bay SE of Brennan Channel, just beyond Middle Ground Shoal and south of Dinner Key Channel.

8 WEATHER LIMITATION (Course and Starting)

8.1 [NP] The wind speed ranges in ROC 9 will apply on the choice of course, and decisions to start, change or abandon races.

9 COURSES

9.1 The diagrams in SI Addendum A show the courses, their designations, the approximate angles between legs, the order in which marks are to be passed, and the side on which each mark is to be left.

9.2 The course length will be based on sailing conditions. This changes ROC 5.

9.3 No later than one (1) minute prior to the warning signal, the race committee signal vessel will display the course designation and the approximate compass bearing of the first leg. It will remain posted until at least five (5) minutes after the start. This changes RRS 27.

10 MARKS

10.1 The starting mark will be a yellow tetrahedron or race committee vessel.

10.2 Marks 1, 2, 3 and 3s/p (the gate) will be orange tetrahedrons.

10.3 Offset mark 1bis (courses W or W2) will be a small orange cylinder approximately 60 feet to port of mark 1.

10.4 The finishing mark will be either mark 1 (courses with upwind finish) or a green tetrahedron (all other courses).

~~10.5 New marks, as provided in SI 12, are yellow tetrahedron.~~

11 THE START

11.1 The starting line is between a staff displaying an orange flag on the signal vessel at the starboard end and either staff displaying an orange flag on a race committee vessel at the port end or the course side of the port-end starting mark.

11.2 [NP] The race committee may make repetitive sounds as an alert approximately 6 minutes before the start (i.e., 1 minute before the first warning signal).

11.3 RRS 30.4 (Black Flag), shall not be used unless more than 45 boats are entered and at least two general recalls have occurred in that race. This changes RRS 30.4.

12 CHANGE OF COURSE OR THE NEXT LEG OF THE COURSE

12.1 The length of a leg of the course may not be changed by more than 30% of the original leg length. This changes RRS 33.

12.2 A course may be shortened in accordance with RRS 32, but not until after the second windward leg has been completed. This changes RRS 32.

12.3 The race committee may change course being sailed by displaying the new course flag(s) or placards, accompanied by repetitive sounds, before the first boat rounds the mark at which such a change is signaled. This changes RRS 33.

12.4 If mark 1 is **moved**, mark 1bis (offset) will no longer be a mark of the course.

13 THE FINISH

13.1 The finishing line is between a staff displaying a blue flag on the finishing vessel and the course side of the port end finishing mark.

13.2 When the finishing vessel displays flag A while boats are finishing, it means “No more racing for the day”.

14 PENALTY SYSTEM

- 14.1 A boat that takes a penalty in accordance with RRS 44.1 or 44.2 (Penalties at the time of an incident) is requested to notify the race committee promptly upon finishing that race and to inform the race committee of the identity of the other boat involved.
- 14.2 RRS Appendix T1 (Post-Race Penalties) will apply.

15 TIME LIMITS AND TARGET TIMES

15.1 The Mark 1 Time Limit, Race Time Limit (see RRS 35), and the Finishing Window are shown in the table below.

Target Time [NP]	Mark 1 Time Limit	Race Time Limit	Finishing Window
45	30	65	15

- 15.2 If no boat has passed the first mark within the Mark 1 Time Limit, the race will be abandoned.
- 15.3 The Finishing Window is the time for boats to finish after the first boat sails the course and finishes. Boats failing to finish within the Finishing Window, and not subsequently retiring, penalized or given redress, will be scored Time Limit Expired (TLE) without a hearing. A boat scored TLE shall be scored points for the finishing place one more than the points scored by the last boat that finished within the Finishing Window. This changes RRS 35, A5.1, A5.2 and A10.

16 HEARING REQUESTS

- 16.1 As a courtesy, a boat intending to protest should notify the race committee immediately after finishing a race and provide the identity of the protested boat(s).
- 16.2 The protest time limit is 60 minutes after the signal vessel docks, or 45 minutes after the race committee ashore announces no more racing today. These times will be posted on the notice board. Hearings will be held in the meeting room on the second floor at CGSC.
- 16.3 Scoring Inquiries and Starting Penalty Inquiries
- (a) Forms for scoring inquiries, including potential redress requests relating to a starting penalty, should be initiated by filling out the online scoring inquiry form at: <https://forms.gle/UtVpSLen9NhYGqjDZ>.
 - (b) Alternatively, a completed scoring inquiry form may be photographed and emailed to ScoringInquiry@cgsc.org. The race committee will investigate and respond by email. If the scoring inquiry turns into a redress request, then the redress time limit will have been satisfied if the Scoring Inquiry form was submitted before the redress time limit expired.
- 16.4 Hearing Requests
- (a) Protests and requests for hearings unrelated to a starting penalty should be initiated by filling out the online hearing request form at: <https://forms.gle/kzBWozHdzMxarmfjb9>.
 - (b) If a diagram is required, it should be photographed and emailed to Protest@cgsc.org.
 - (c) Alternatively, a completed hearing request form may be photographed and emailed to Protest@cgsc.org.
- 16.5 Notices will be posted as soon as practical after a hearing request is filed to inform competitors of hearings in which they are parties or named as witnesses.
- 16.6 The race committee will post a list of boats that have been given penalties by the race committee. If this list is posted prior to the protest time limit, then requests for redress based on this posting shall be filed no later than thirty (30) minutes after the protest time limit. This changes RRS 61.2(b).
- 16.7 Notices of protests by the race committee, protest committee, or technical committee will be posted to inform boats under RRS 60.2(a)(2).
- 16.8 It is each boat's sole responsibility to check the notice board or their e-mail to see if they are cited in a protest. Should any party fail to appear when called for a hearing, the protest committee may proceed in accordance with RRS 63.1(b). Representatives of boats who are parties to hearings and their witnesses shall remain on call until excused by the protest committee.

17 SCORING

17.1 One (1) race is required to be completed to constitute an event.

17.2 A boat's series score is the total of her race scores.

18 SAFETY REGULATIONS

18.1 [SP] Before the start of their first race each day, a boat shall check-in by sailing past the stern of the race committee signal vessel, hailing their sail number, and receiving a verbal acknowledgement from the race committee. Failure to do so, will result in a scoring penalty as follows: points will be added to the boat's score in the first race they finish that day equal to 10% of the starters in that race. This changes RRS Appendix A10.

18.2 [DP] A boat that retires from a race shall notify the race committee at the first reasonable opportunity.

19 REPLACEMENT OF CREW OR EQUIPMENT

19.1 [DP] Substitution of competitors is not allowed without prior written approval of the race committee. Once a skipper and/or crew have been excused, they may not return for the rest of the event.

19.2 Co-skippers are allowed subject to the restrictions of SI 20.1.

19.3 [DP] Substitution of damaged or lost equipment is not allowed unless authorized in writing by the race committee. Requests for substitution shall be made to the committee at the first reasonable opportunity, which may be after the race.

20 [DP] SUPPORT TEAMS

20.1 Support vessels shall be equipped with a functioning engine safety cut-out switch (kill switch) which shall be attached to the helmsman at all times while the engine is running.

20.2 Support vessels shall display the flag provided by the OA at registration at all times while on the water. A support person will be charged \$80 if the flag is not returned at the end of the event.

20.3 Support vessels are expected to render assistance to a boat in danger when requested by the boat, or at the request of the race committee, protest committee, or technical committee.

20.4 Support vessels shall monitor the race committee VHF channel (see SI 3) during the race.

20.5 Support vessels shall stay 100 meters outside areas where boats are racing from the time of the preparatory signal for the first start until all boats have finished or retired or the race committee signals a postponement, general recall, or abandonment.

20.6 Drones operated by support persons shall stay 500 meters outside areas where boats are racing from the time of the preparatory signal for the first start until all boats have finished or retired or the race committee signals a postponement, general recall, or abandonment.

21 TRASH DISPOSAL

21.1 Trash may be placed aboard official or support person vessels.

22 PRIZES

22.1 Prizes shall be awarded in accordance with the NoR.

23 RISK STATEMENT

24.1 RRS 3 states: 'The responsibility for a boat's decision to participate in a race or to continue to race is hers alone.' By participating in this event each competitor agrees and acknowledges that sailing is a potentially dangerous activity with inherent risks. These risks include strong winds and rough seas, sudden changes in weather, failure of equipment, boat handling errors, poor seamanship by other boats, loss of balance on an unstable platform and fatigue resulting in increased risk of injury. **Inherent in the sport of sailing is the risk of permanent, catastrophic injury or death by drowning, trauma, hypothermia or other causes.**

SI Addendum A – Courses

Notes:

- The course will be designated on a placard on the starboard side of the race committee vessel.
- At a leeward gate, if only one mark is set, then the mark shall be rounded to port.

Course W

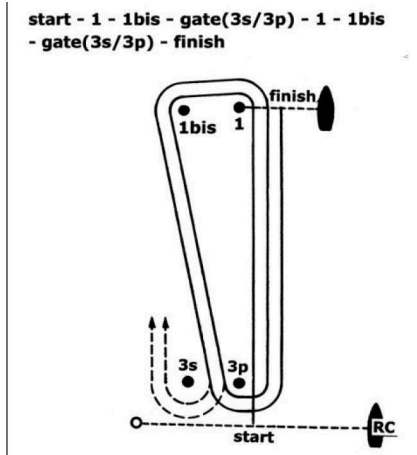

Course O

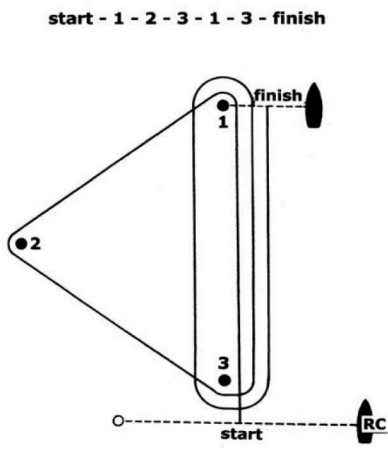

Course T

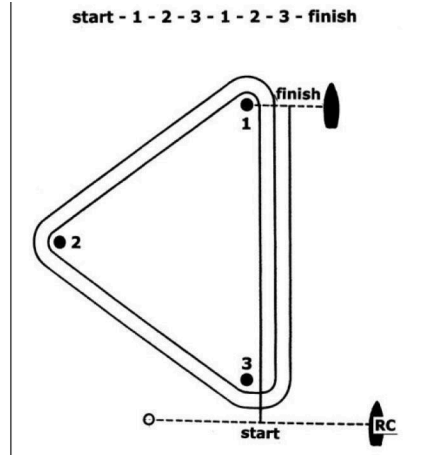

Course W2

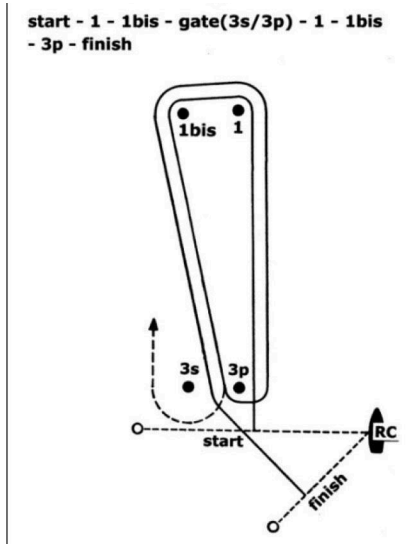

Course O2

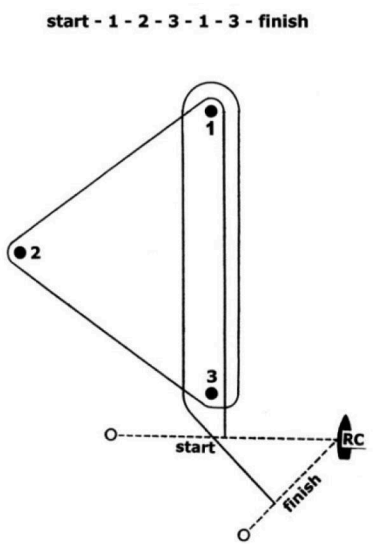

Course T2

