



**59<sup>th</sup> ANNUAL DON Q SNIPE REGATTA**  
**APRIL 4-6, 2025**  
**COCONUT GROVE SAILING CLUB**  
**& SNIPE FLEET #7**  
**SAILING INSTRUCTIONS**  
**Posted April 1 2025**



**1. RULES:**

- 1.1. The event will be governed by the *rules* as defined in the current edition of the *Racing Rules of Sailing* (RRS), the current SCIRA Class Rules, By-Laws, and the by the SCIRA 2025 Non-Championship Rules of Conduct ("ROC"), the Notice of Race (NOR), and these Sailing Instructions (SI). The ROC are included as a race document on the Regatta Network event site.
- 1.2. The following Prescriptions of US Sailing will apply: Appendix R, the prescription to the preamble to Part 5, and the prescriptions to RRS 65.1, 70.3(b), 76.1 and 88.2. The full text of these US Prescriptions will appear as a race document on the event website.
- 1.3. The following *rules* are being amended by these SI: RRS 26, 27.1, 30.4, 32, 33, 35, 60, 61.2, 61.4(b)1, 63.5(c), Appendix A2, Appendix A5, Appendix A10, Appendix P and Race Signals.
- 1.4. The following ROC are being amended by these SI: ROC 5, 8.1, 9.1 and 9.2.
- 1.5. In accordance with the SCIRA Advertising Prescription, this event shall comply with World Sailing Regulation 20.
- 1.6. Appendix P - Special Procedures for Rule 42, will not apply. However, P2.1 will apply for all penalties. P2.2 and P2.3 are deleted.
- 1.7. If there is a conflict between the NOR and the SI, the SI shall govern. This changes RRS 63.5(c).
- 1.8. The race committee (RC) will use the Vakaros RaceSense system, providing relevant information to all boats. Refer to **Addendum F** and the official notice board for instructions, rules and details.

**2. NOTICE TO COMPETITORS:**

- 2.1. All race documents, notices & results will be posted on the official notice board at Regatta Network, [https://www.regattanetwork.com/event/28577#\\_newsroom](https://www.regattanetwork.com/event/28577#_newsroom). Failure of a boat to read any such postings will not be grounds for redress. This changes RRS 61.4(b)1.
- 2.2. On Thursday, April 3<sup>rd</sup> at 1830, there will be a competitor's briefing at CGSC.
- 2.3. The RC will be using VHF channel 73.
- 2.4. On-shore, the Organizing Authority, Protest Committee and RC will communicate to the fleet via the "Miami Snipe Fleet 7" WhatsApp chat. It is the responsibility of each entry to have at least one person signed up for the WhatsApp notices.
- 2.5. Sailors can join the chat using link <https://chat.whatsapp.com/C4MZoyTXe7wCxaidpjofOJ>

**3. CHANGES TO SAILING INSTRUCTIONS:**

- 3.1. Any change to the SI will be posted no later than 90 minutes before the race day's initial warning signal, except that any change to the schedule of races will be posted by 1900 hours on the day before it will take effect.
- 3.2. Any change or amendment to the SI shall have the prior approval of the PRO.
- 3.3. Oral changes to the SI may be given on the water. The RC signal vessel shall display flag "L" and announce via megaphone in accordance with RRS 90.2(c). Competitors may also approach the signal vessel and verbally receive the change or read it from a whiteboard while flag "L" is displayed.

**4. SIGNALS MADE ASHORE:**

- 4.1. Signals made ashore will be displayed at the CGSC flag hoist and will be communicated in the event WhatsApp group.
- 4.2. When flag AP is displayed ashore, "1 minute" is replaced with "not less than sixty (60) minutes" in the race signal AP. This changes RRS Race Signals.
- 4.3. In the event of an onshore postponement, the RC will communicate to competitors via WhatsApp.

## 5. SCHEDULE OF RACES:

- 5.1. The maximum number of races to be sailed is eight (8).
- 5.2. The maximum number of races that can be sailed on one day is three (3).
- 5.3. The first warning signal will sound at 1100 on Friday, Saturday and Sunday.
- 5.4. No warning signal will be made after 1430 on Sunday.

## 6. CLASS FLAG:

The Class Flag will be a white flag with the Snipe insignia/emblem.

## 7. RACING AREA:

The Racing Area will be on Biscayne Bay SE of Brennan Channel, just beyond Middle Ground Shoal and south of Dinner Key Channel.

## 8. COURSES & CONDITIONS:

- 8.1. The diagram in **Addendum A** shows the courses, the order in which the marks are to be passed, and the side on which each mark is to be left. The course length will be based on sailing conditions. This changes ROC 5.
- 8.2. No later than one minute before the warning signal, the RC signal vessel will display the course to be sailed and the approximate compass bearing to Mark 1 in yellow digital letters/numbers, on a black board, not signal flags. This changes ROC 8.2.
- 8.3. The display of the course board will be accompanied by one (1) sound signal and will remain displayed for four (4) minutes after the start. Timely removal of the course board shall not be grounds for redress. This adds to RRS 27.1.
- 8.4. All marks must be left to port unless it is a gate or the "start/finish mark" when finishing.
- 8.5. **Mark 3 for course W and W2 will be a gate, 3 s/p.**
- 8.6. No race will be started in less than a sustained 4 knots of wind. However, the RC may, in its discretion, decline to begin a race in less than a sustained 5 knots of wind. This changes ROC 9.1.
- 8.7. No race will be started in more than 23 knots of sustained wind, or in conditions where the winds are gusting to more than 27 knots. The RC may abandon any race if there are sustained winds over 18 knots.

## 9. MARKS:

- 9.1. Marks 1, 2 and 3 s/p will be orange tetrahedrons.
- 9.2. Any start or finish mark, if one is set, will be a green tetrahedron.
- 9.3. For the Windward/Leeward course(s) (course "W" or "W2"), an orange cylinder will be set as an offset mark approximately sixty feet to port of Mark 1.
- 9.4. The RC signal vessel may set an inflatable buoy attached to its stern. The inflatable buoy and its attachment line are a limit mark and must be left to starboard when starting, and when finishing downwind it must be left to port.
- 9.5. For a change of course, new marks will be yellow tetrahedrons. If a subsequent change is needed, it will follow with the original mark.

## 10. THE START:

- 10.1. The starting line will be the course side of a line between a staff displaying an orange flag or shape on the RC signal vessel at the starboard end and the port-end start/finish mark, or between a staff displaying orange flags on two RC vessels.
- 10.2. All races will start in accordance with RRS 26, as modified by Addendum F.
- 10.3. No boat may start a race more than four (4) minutes after the starting signal for that race, and will be scored Did Not Start (DNS) without a hearing. This changes ROC 8.1, and RRS 35.
- 10.4. The starting line will be set downwind of Mark 3 (leeward mark or 3 s/p the gate). Mark 3 is not a mark of the course for the first leg of the race.
- 10.5. Six (6) minutes before the start, the RC will make multiple short sounds as an alert to the warning signal.

## 11. CHANGE OF COURSE OR NEXT LEG OF THE COURSE:

- 11.1. Shortening or lengthening the next leg of the course may not be by more than 30% of the original leg length. This changes RRS 33. The number of legs of a course may not be reduced until after the

second windward leg has been completed. This changes RRS 32. If the RC elects to change the course being sailed to a different designated course, such a change will be signaled by the display of the appropriate flag and a course board with the new course description, accompanied by repetitive sounds before the lead boat rounds the mark at which such a change is signaled. This modifies RRS 33 and changes ROC 9.2.

- 11.2. Except at a gate, boats shall pass between the RC boat signaling the change and the nearby mark, leaving the mark to port and the RC boat to starboard.

## 12. THE FINISH:

- 12.1. For courses "W" and "T", the finish line shall be the course side of a line between a staff displaying a blue flag on a RC boat at the starboard end and Mark 1 at the port end.
- 12.2. For courses "W2" and "T2", the finish line shall be the course side of a line between a staff displaying a blue flag on the RC boat at the port end and the start/finish mark at the starboard end, or between staffs displaying blue flags on two RC boats.
- 12.3. The finish line for course T2 will be set square to the last reach leg, below the start line.
- 12.4. The finish line for course W2 will be set at an angle below the start line. Please see Addendum A.

## 13. PENALTIES:

- 13.1. Any competitor taking a penalty in accordance with RRS 44.1 or 44.2 (*Penalties at the time of an incident*) is requested to notify the RC promptly upon finishing that race and to inform the RC of the identity of the other boat involved.
- 13.2. Any boat failing to check-in (CNF), in accordance with SI 17.1, will receive a scoring penalty. Points will be added to its finishing position equal to 10% of the starters in that race. This changes RRS Appendix A10.
- 13.3. The black flag may be used only in a fleet of 45 or more starters and only after two or more general recalls. This changes RRS 30.4.
- 13.4. A boat failing to finish a race will be scored DNF without a hearing and will be awarded points equal to one more than the number of boats finishing that race. This changes RRS A5.2.

## 14. TIME LIMIT:

- 14.1. The time limit for the first boat to finish shall be 65 minutes. Should the first boat fail to finish within the aforementioned time the RC shall abandon the race.
- 14.2. Should the first boat fail to complete the first lap within 30 minutes, the RC shall abandon the race. For the purpose of this Rule a lap shall mean the rounding of Mark 3, or 3 s/p (gate) for the first time.
- 14.3. Boats failing to finish within 15 minutes after the first boat sails the course and finishes will be scored DNF, and one (1) point more than the number of boats finishing within the time limit, without a hearing. This changes RRS Appendix A5.

## 15. PROTEST AND REQUEST FOR REDRESS:

- 15.1. A competitor's intent to protest shall be reported to the RC promptly upon finishing the race in which the incident occurred. This changes RRS 60. The protestor must still otherwise comply with RRS 60.
- 15.2. Protests must be filed within one (1) hour after the RC finish boat docking time or when a race is abandoned ashore. The protest time limit will be posted on the regatta website notice board and be sent out via WhatsApp.
- 15.3. Request for Redress filing time shall be no later than the protest time limit or 30 minutes after the incident or 30 minutes after the posting of penalty/decision, whichever is later. This changes RRS 61.2.

- 15.4. Scoring inquiries, **including potential redress requests relating to a starting penalty**, should be initiated by filling out the online Scoring Inquiry form at <https://docs.google.com/forms/d/e/1FAIpQLSc56x9WKwLpBLRiQE5NOPGtKmntlVJQTe6-IWpISgVouz5qIQ/viewform>. Alternatively, a completed Scoring Inquiry form may be photographed and emailed to [ScoringInquiry@cgsc.org](mailto:ScoringInquiry@cgsc.org). Also, questions about the status of scoring inquiries can be emailed to [ScoringInquiry@cgsc.org](mailto:ScoringInquiry@cgsc.org). The RC will investigate, get back to you, and attempt to resolve the issue. If the scoring inquiry turns into a redress request, then the redress time limit will have been satisfied if the Scoring Inquiry form was submitted before the redress time limit expired.
- 15.5. Protests and **requests for redress unrelated to a starting penalty** should be initiated by filling out the online Protest form at [https://docs.google.com/forms/d/e/1FAIpQLSdzOkZE7vvK\\_ixfJzfTr2txULYBp3CoQitoEphz2aVXlvU5lQ/viewform](https://docs.google.com/forms/d/e/1FAIpQLSdzOkZE7vvK_ixfJzfTr2txULYBp3CoQitoEphz2aVXlvU5lQ/viewform). Additionally, if a diagram is required, it should be photographed and emailed to [Protest@cgsc.org](mailto:Protest@cgsc.org). Alternatively, a completed Protest form may be photographed and emailed to [Protest@cgsc.org](mailto:Protest@cgsc.org). Also, questions about the status of protests and redress requests can be emailed to [Protest@cgsc.org](mailto:Protest@cgsc.org).
- 15.6. Protest notices and hearing schedules specifying the protesting and protested parties will be posted no later than one-half hour after the expiration of the protest filing time limit. It is each boat's sole responsibility to check the event website notice board or its e-mail promptly after the end of the protest filing time to see if she is cited in a protest. Representatives of boats who are parties to hearings and their witnesses shall remain on call until excused by the Protest Committee.
- 15.7. Protest hearings will be held in person, upstairs, at CGSC.
- 15.8. After a hearing, penalties for breaches of rules other than Part 2 or RRS 31 that do not specify a penalty may be at the discretion of the Protest Committee.

## 16. SCORING:

- 16.1. One (1) completed race will constitute a series for this event.
- 16.2. A boat's series score will be the total of her race scores. No race result will be excluded. This changes RRS Appendix A2.1.

## 17. SAFETY REGULATIONS:

- 17.1. Each day before the start of the first race, while flag "L" is displayed, each boat is required to sail on starboard tack past the stern of the RC signal boat, verbally check in and be acknowledged by the RC.
- 17.2. A boat that retires from a race shall notify the RC as soon as possible.

## 18. REPLACEMENT OF CREW:

- 18.1. The same crew shall race in all races.
- 18.2. Requests for the replacement of any member of the crew shall be submitted in writing to the PRO prior to 0900 on the day the change will take effect.
- 18.3. The request for replacement of any member of the crew requires the approval of the PRO.
- 18.4. Once a skipper and/or crew have been excused, they may not return for the balance of the series.

## 19. EQUIPMENT AND MEASUREMENT CHECKS:

The RC may inspect competitors, or boats, at any time. Equipment inspections may be initiated at the finish of any race.

## 20. SUPPORT BOATS:

- 20.1. Coach vessels shall register with CGSC during Registration, receive a flag, and sign a credit card authorization. Upon request, a mooring ball will be assigned for overnight use. The vessel will be charged \$80 if the flag is not returned at the end of the regatta. No coach vessel will be allowed on the course without a flag.
- 20.2. No coach, other support or spectator vessels shall operate within 150 meters of the race course except to render assistance. Any competitor associated with personnel determined to have violated this rule shall be subject to protest and assessed a 20% penalty for the race in which the violation occurred.

**20.3.** Any coach, RC support vessel, or spectator vessel being operated singlehandedly in the immediate vicinity of, and associated with, this event shall have a kill switch lanyard attached to the operator as long as the engine is running.

**21. DISCLAIMER OF LIABILITY:**

Competitors participate in the event entirely at their own risk. See RRS Rule 3, Decision to Race and RRS 4, Acceptance of Rules. The Organizing Authority will not accept any liability for material damage or personal injury or death sustained in conjunction with or prior to, during or after the regatta. **By entering this regatta, you accept this condition.**

## SI Addendum A – Courses

### Notes:

- The course will be designated on a placard on the starboard side of the race committee signal vessel.
- At a leeward gate, if only one mark is set, then the mark shall be rounded to port.

### Course W

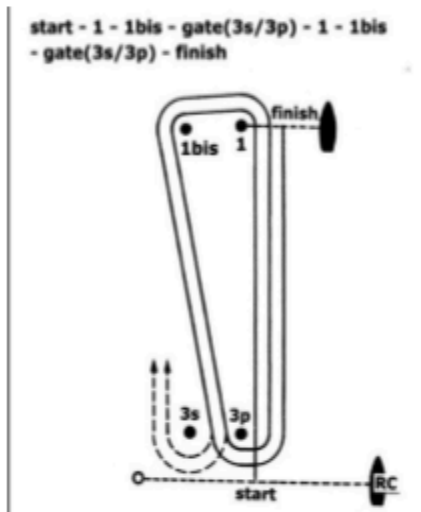

### Course T

start - 1 - 2 - 3 - 1 - 2 - 3 - finish

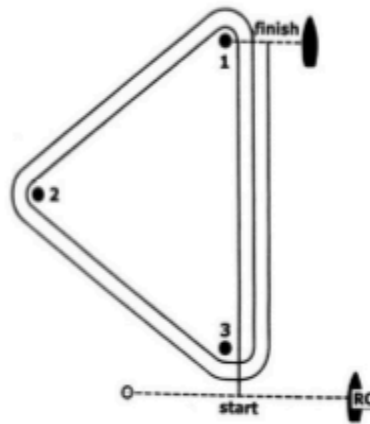

### Course W2

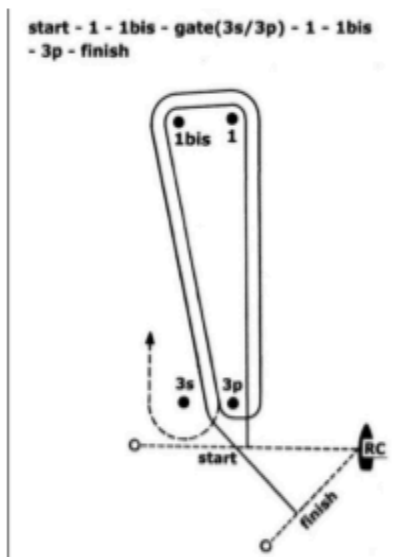

### Course T2

start - 1 - 2 - 3 - 1 - 2 - 3 - finish

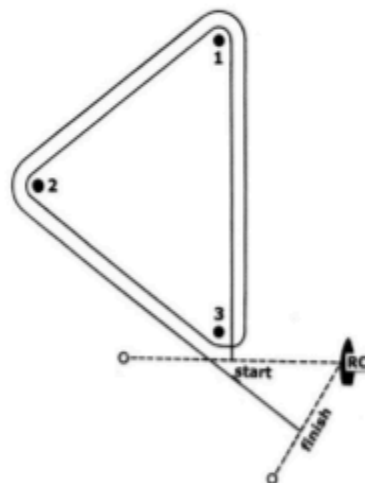

## SI ADDENDUM F - Vakaros RaceSense RRS changes

### [NP]Rules and Instructions for Using the Vakaros and RaceSense System

F.1 Each boat shall have a working Vakaros Atlas 2 or Atlas Edge configured for RaceSense at check-in. Boats without a configured Atlas 2 or Atlas Edge may have one loaned by Miami Snipe Fleet 7. This shall be mounted and secured as required by the class at all times while racing.

F.2 The Vakaros RaceSense system will be used by the Race Committee (RC) and the relevant information will be available to all boats.

F.3 Instructions for using the electronic Atlas 2 or Atlas Edge device will be posted on the ONB.

F.4 Competitors shall take all reasonable measures to keep the Atlas 2 or the Atlas Edge secure and operational and promptly notify Vakaros staff on the water or ashore of any device issues.

F.5 RRS 26 is changed. The countdown to the start on the Atlas 2 or Atlas Edge from RaceSense will be the official time. Signal flags will be used for information purposes only.

F.6 The visual identification of boats infringing RRS 29 and 30 by the RC is replaced with electronic identification through the Vakaros RaceSense system, modifying RRS 29.1, 30.1, 30.2, 30.3, and 30.4.

F.7 Any failure of the Atlas 2 or Atlas Edge, RaceSense system, or communication systems, will not constitute grounds to request redress by a boat or the Protest Committee. This changes RRS 41(c), 61.1(a), 61.1(c).

F.8 If the RC vessel displays code flag Oscar (with one sound) before the warning signal of a race, F.5 and F.6, inclusive, will not apply to that race.

F.9 If the RC vessel displays code flag Romeo (with one sound) before the warning signal of a race, Competitors shall restart their Vakaros Atlas 2 or Atlas Edge unit by switching it off, waiting 10 seconds and then switching it back on to reconnect to the RaceSense network. Code flag Romeo will remain displayed for a minimum of two (2) minutes and will be removed with the next signal.

F.10 If there is an issue with a Vakaros unit during the starting sequence:

F.10.1 The RC will display AP, followed by the display of code flag Lima (with one sound). Competitors shall come to the RC Signal vessel for further instructions.

F.10.2 Per F.10.1, the RC may additionally display either code flag Romeo (with one sound) indicating restart your Vakaros units, or code flag Oscar (with one sound) indicating the RC is turning off Vakaros for that start (F.5 and F.6, inclusive, will not apply to that race), or strike AP.

F.11 Once any issues have been resolved, and the new start time has been programmed to the Vakaros units, one (1) minute prior to the warning signal, all signal flags will be removed.

F.12 If firmware updates to Atlas 2 or Atlas Edge devices are required between scheduled race days, a notice will be sent to all boats via email and/or WhatsApp.