

SBYC Wednesday Night Series 2024

Sailing Instructions



1. RULES

- 1.1. Races will be governed by the Racing Rules of Sailing (2021-2024) ([ISAF-RRS](#)), and these Sailing Instructions.
- 1.2. ***All boats shall provide to the race committee a completed registration form. To register, go to the Regatta Network's Event page.***
- 1.3. Updates to a boat's registration information (e.g. contact info, sail #'s, etc...) shall be provided by updating the registration information on Regatta Network.

2. NOTICES TO COMPETITORS

- 2.1. The official Notice Board will be the [Wednesday Night Notice Board page](#) the Sapphire Bay Yacht Club website.

3. CHANGES IN SAILING INSTRUCTIONS

- 3.1. Any changes to these Sailing Instructions will be posted on the Official Notice Boards 24 hours prior to the scheduled start time of the race in which it will take effect.

4. SIGNALS

- 4.1. **All signals shall be announced via radio broadcast**, on Channel 71 (see Section 16 RADIO COMMUNICATION)
- 4.2. VHF radio is required. Course change announcements, over early calls, and other important communications will be over VHF Channel 71.

5. SCHEDULE OF RACES

- 5.1 Races will be conducted per the schedule posted on the Official Notice Board (see *Section 2 NOTICES TO COMPETITORS*)
- 5.2 Unless agreed to otherwise, and posted in advance, only one race is scheduled per day.

6. FLEET ASSIGNMENTS AND CLASS FLAGS

- 6.1. The fleets designated for each sailing series will be as follows:
 - "A" - boats with PHRF less than 121
 - "B" - boats with PHRF greater than or equal to 121 and less than 212
 - "C" - boats with PHRF greater than or equal to 212
 - "D" - boats with displacement over 6,500 pounds.
 - "E" - boats with novice/casual skippers

SBYC Wednesday Night Series 2024

Sailing Instructions



- 6.2. A boat that classifies for the “D” AUX fleet may instead race a series with the fleet designated by their PHRF rating (A,B, or C). Any boat may register for “E” Fleet.
- 6.2.1 Displacement fleet boats declaring that they wish to sail in the fleet designated by their PHRF rating (A, B, or C) shall notify the scorer prior to the beginning of each series and shall sail the entire series in that fleet.**
- 6.3. There WILL NOT BE a separate fleet designation for the “Main and Jib” boats. “Main and Jib” boats will sail in the fleet designated by Sections 6.1 and 6.2.
- 6.3.1 Boats declaring that they wish to sail as “Main and Jib” (MJ) shall notify the scorer prior to the beginning of each series and shall sail the entire series under main and jib alone.**
- 6.4. Race Committee shall not add any additional fleets to any race or series without prior approval of senior race officers from each club.
- 6.4.1 There will be three starts:
- Start 1: A & B Fleets
 - Start 2: C & D Fleets
 - Start 3: E Fleet
- 6.4.2 At the discretion of the race committee, additional starts may be used.
- 6.5 Start designation:
- 6.5.1 The first starting fleet(s) will be designated as starting class one, represented by the class flag “Numeral 1”.
- 6.5.2 The second starting fleet(s) will be designated as starting class two, by the class flag “Numeral 2”.
- 6.5.3 Additional fleet starts will be designated by corresponding Numeral flags

7. RACING AREA

- 7.1. The racing area is on Lake Ray Hubbard, South of Interstate 30 (see Appendix 2,3: Map - Lake Marks)

8. MARKS

- 8.1. The marks of the course will be the permanent marks/buoys of the lake as described in Appendix A. Each of the marks has been marked with a numeric designation as shown on the map. GPS coordinates for each of these marks are provided. See Appendix 3: Locations - Lake Marks and the SBYC web page for a GPX file.
- 8.2. If the permanent marks are not used to conduct a race, the Race Committee will post the Come Within Hail flag and signal the use of other marks. Race Committee will be required to measure and supply the scorer with the relevant distances to the temporary mark.

SBYC Wednesday Night Series 2024

Sailing Instructions



8.3. Missing Mark

8.3.1 If a support boat is available and able to remain on-station, she may serve as a temporary replacement mark.

8.3.2 Otherwise, the race shall be abandoned. If possible, a new start shall be attempted.

9. THE COURSE

9.1 The course to be sailed will be designated and announced by the race committee prior to the first warning signal of the day.

9.1 Leave all marks to Port.

9.1.1 **Poison Line:** If the start/finish line is a *mid-course line*, then the line will be Closed (boats may not pass through the line while racing, except to start or finish).

9.2 Course Designations:

9.2.1 Windward/Leeward Courses:

- Windward Mark + W + Number of *Laps*

9.2.2 Modified Windward/Leeward Courses (Mid-Course Line):

- Windward Mark + Leeward Mark + W + Number of Laps

9.2.3 Courses other than Windward/Leeward

- Name the Marks to be *Rounded*, in the order they are to be rounded
- Do not include the Start/Finish pin.

Sample Course Boards

A: 18-2 W2

B: 18-2, 0, 18-1

C: 18-1, 12

D: 18-1, 12, 0, 18-1

A Fleet:

- Windward/Leeward Course
- 18-2 is the Windward Mark
- 2 Laps

B Fleet:

- List of Marks to be rounded
- W/L with different Windward Marks
- Note: S (aka 0) is listed when it is a mark to be rounded, but not listed when it is the Start or Finish.

SBYC Wednesday Night Series 2024

Sailing Instructions



A: 18-2 W2

B: 18-2, 0, 18-1

C: 18-1, 12

D: 18-1, 12, 0, 18-1

C Fleet:

- List of Marks to be rounded
- Triangle

D Fleet:

- List of Marks to be rounded
- Triangle plus W/L

A: 9, 27 W3

B: 9, 27 W2

C: 9, 27 W1

D: 9, 27 W2

A Fleet:

- W/L Course, Mid-Course Line
- 9 is the Windward Mark
- 27 is the Leeward Mark
- 3 Laps

B Fleet:

- Same, but only 2 Laps

C Fleet:

- Same, but only 1 Lap

D Fleet:

- Same, but only 2 Laps

10. THE START

10.1 Abandoning a Race

10.1.1 A race will not be abandoned until after its official warning time, with the following exceptions:

10.1.1.1 Forecast unfavorable conditions: the Race Committee (utilizing Go/NoGo reference data) shall notify all racers that the day's race will be abandoned, but shall not make this notification more than 24 hours prior to a day's race.

10.1.1.2 Extraordinary circumstances

10.2 Abandonment more than 3 hours prior to a day's race will be posted on the Official Notice Board (See 2 - Notices to Competitors)

SBYC Wednesday Night Series 2024

Sailing Instructions



- 10.3 All boats shall endeavor to check-in with the Race Committee boat prior to the warning signal of each day's race. Check-in may be done via radio communications with the Race Committee at least 5 minutes prior to the warning signal of the day's race. Race Committee may, at its discretion, waive this requirement for a day's race.
- 10.4 The starting line will be between a staff displaying an orange flag on the committee boat (anchored) at the starboard end and the port end **Starting Mark**, or between the permanent **Starting Mark** and a temporary mark. (see Appendix 1: Courses) When using two marks for the starting line, the committee boat shall be on station at the starboard end of the starting line, at anchor or underway.
 - 10.4.1 The **Starting Mark** will be either Mark S (zero) or Mark 18-1. (see Appendices 2 & 3)
 - 10.4.2 **Starting line length:** It is recommended that the race committee set a starting line of a minimum 600 feet on Wednesday Nights. (Rule of Thumb - start line length should be approximately 1.5 times the total length of all boats in the largest starting fleet).
- 10.5 Race committee shall endeavor to set the line perpendicular to the wind.
- 10.6 Starts will be timed with the club SailBot timer app and horn box. Signal flags will be displayed as prompted by the SailBot app. Sound signals will be generated by the SailBot horn. If possible, sound signals will be transmitted over VHF radio.
- 10.7 Not later than the warning signal, the Race Committee signal boat will display the selected courses on the display board and announce them over the VHF radio.
- 10.8 **Boats whose warning signal has not been made shall avoid the starting area.**
- 10.9 To call attention to the starting sequence, the SailBot start timer will be configured to make a five (5) horn signal one minute before the beginning of the first starting sequence. If used, the Postpone signal flag will be removed at this time.
- 10.10 Races will be started using the signals defined in RRS 26. When more than one start is planned for a day's racing, a rolling start sequence will be used, with the warning signal for each succeeding class made with the starting signal of the preceding class.
- 10.11 A boat starting later than 15 minutes after her starting signal will be scored (DNS), Did Not Start. This changes rule A4.
- 10.12 Races will not be started prior to the scheduled start time.

11 . CHANGE OF COURSE AFTER THE START

- 11.2 Race Committee will only change a course at the **Starting Mark** or other mark of the course.
 - 11.2.1 A Change of Course may only occur prior to the first boat rounding the **Starting Mark** or other mark of the course used for the course change.
- 11.3 The Change of Course will be signaled via radio.
- 11.4 The "+" and "-" symbols will not be used to indicate a course that has been lengthened or shortened. This changes *Racing Rule 33*.
- 11.5 Temporary Marks may be moved without notification.

SBYC Wednesday Night Series 2024

Sailing Instructions



12 . THE FINISH

12.2 The finish line will be between:

12.2.1 A staff displaying an orange flag on the Race Committee boat at the starboard end, and the ***Starting Mark*** or other mark of the course, at the port end.

12.2.2 The ***Starting Mark*** or other mark of the course, and a temporary mark. The race committee boat shall be on the starboard end at anchor or underway taking finishes. At the discretion of the race committee, the finish line may be shortened to a minimum of 100 ft. length.

12.2.3 When two marks are used as the starting line, two marks shall be used as the finish line.

12.2.4 Race Committee shall finish the boats racing as the leading most part of the hull crosses the finish line, per current RRS.

12.2.5 All boats racing, retiring early (not intending to finish), shall notify the Race Committee at its earliest convenience. (See section 16 Safety).

13 . TIME LIMIT

13.2 The time limit for the first boat to finish a Wednesday evening race will be 120 minutes (2 hours) from the start. Any boat not finishing within 150 minutes (2.5 hours) of the start will be scored DNF.

14 . SCORING

14.2 The Low-Point Scoring System, rule A2 will apply.

14.3 Starting at 5 races, add 1 throw out. At 8 races, add 1 more throw out.

14.4 Boats scored as DNS, OCS, DNF, or DSQ shall be scored points for the finishing place, one more than the number of boats entered in the days race. (DNS shall only be scored for those boats that endeavored to come to the starting area).

14.5 Boats scored as DNC shall be scored points for the finishing place, one more than the number of boats entered in her fleet for the series.

14.6 Scoring for Race Committee:

14.6.1 A boat serving Race Committee duty shall receive for that race a score equal to the average of scores they received for other races in that series, for one race. Additional races served as Race Committee duty in that series shall be scored DNS.

14.6.2 A boat serving Race Committee duty shall be scored as RC.

14.7 A boat that makes contact with the Race Committee boat shall be scored as DSQ. This changes *Racing Rules 63.1 and/or A5*.

SBYC Wednesday Night Series 2024

Sailing Instructions



15 . PROTESTS

- 15.2 The Protest Time Limit is 24 hours from the first warning signal of the night.
- 15.3 Protest Forms shall be filed (in person or attached to an email) with an officer of SBYC.

16 . RADIO COMMUNICATION

- 16.2 The race committee will monitor VHF channels 16 and 71. All communications with the race committee should be done on channel 71, or by check-in. All communications after the start of the race should be made via VHF radio so that the information is shared by all competitors. After acknowledged contact on VHF channel 16, the race committee will direct the hailing boat to switch to channel 71.
 - 16.2.1 In case of an emergency, a vessel in distress should hail on Marine VHF channel 16. If you are unable to reach the appropriate authorities or Race Committee, consider attempting to hail Race Committee on channel 71 and channel 16. Repeat sequence as necessary.
- 16.3 Radio communications with the race committee during the starting sequence is discouraged, and will only be answered at the discretion of the race committee, or in the event of an emergency.
- 16.4 The race committee will endeavor to hail individual recalls. Hails will also be broadcast on VHF channel 71.

NOTE: DON'T FORGET to bring your VHF RADIO. Race Committee will use channel 71 to radio information to the competitors before and during the start sequence. Race Committee will radio the fleet on channel 71 as to the course for the day's race. Also, monitor channel 71 for course changes, and as a means to "stay connected" to the fleet during the race, and in case any boat radios a distress message. If you do not have a working VHF radio, arrive early enough to check in with the Race Committee to receive the course.

17 . SAFETY, ASSUMPTION OF RISK AND RELEASE

- 17.2 It shall be the sole responsibility of each yacht to decide whether to start or continue a race.
- 17.3 All boats participating are asked to check in with the committee boat prior to the Warning signals of each race.
- 17.4 A yacht that retires from a race shall attempt to notify the race committee before leaving the course area. See 15 Radio Communications.
- 17.5 Competitors participate in each racing series entirely at their own risk. See Racing Rules of Sailing (2021-2024) rule 3, Decision to Race. The organizing authority will not accept liability for material damage or personal injury or death sustained in conjunction with, or prior to, during or after the racing.

SBYC Wednesday Night Series 2024

Sailing Instructions



- 17.6 To the fullest extent permitted by law, participants waive any rights they may have to sue the race organizers (organizing authority, race committee, protest committee, host club, sponsors, or any other organization or official) involved with the event with respect to personal injury or property damage suffered by the participant or their crew as a result of participation in this event and release the race organizers from any liability for such injury or damage.
- 17.7 Other Misc Safety Information:
BE AWARE: All competing boats should already have an emergency plan in place to immediately retrieve a crew person who inadvertently falls overboard. All boats within close proximity to this type of emergency should be prepared to render aid.

SBYC Wednesday Night Series 2024

Sailing Instructions



Appendix 1: Courses

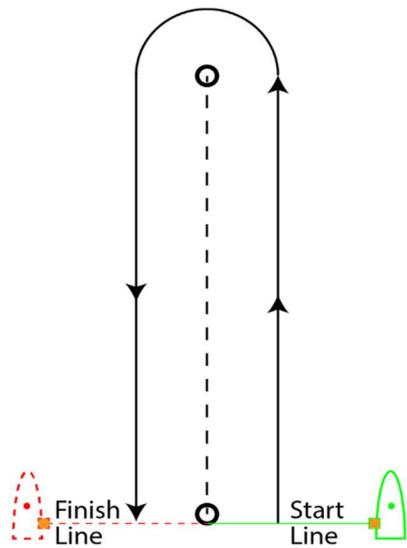

W1
Windward/Leeward
1 Lap

Downwind Start

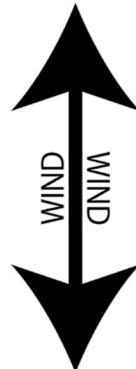

Upwind Start

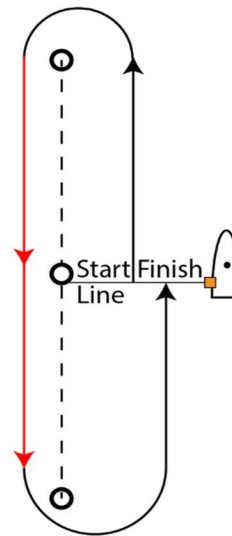

WM1
Windward/Leeward
Mid-Course Line
1 Lap

These legs can pass to either side of the Start/Finish Line, but **not through** it

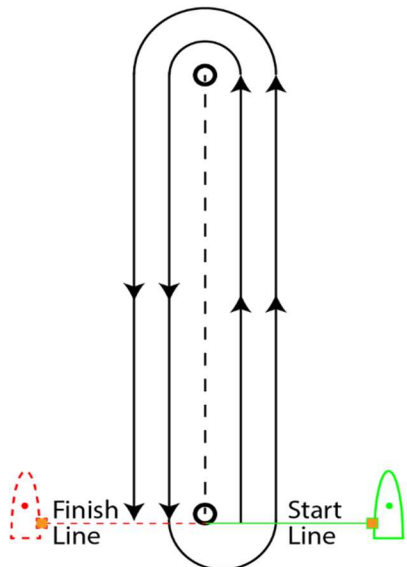

W2
Windward/Leeward
2 Laps

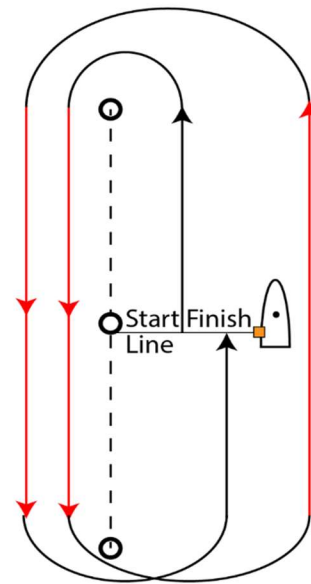

WM2
Windward/Leeward
Mid-Course Line
2 Laps

SBYC Wednesday Night Series 2024

Sailing Instructions



Appendix 1: Courses

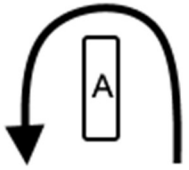

Windward/Leeward Course	
A W1	Start-A-Finish
A W2	Start-A-S-A-Finish
A W3	Start-A-S-A-S-A-Finish

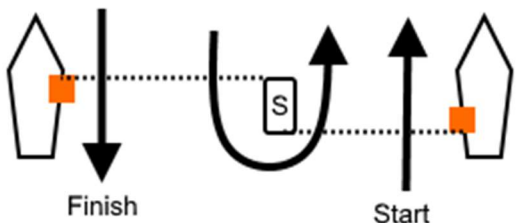

Finish Start

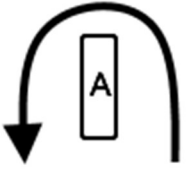

Windward/Leeward Course Mid-Course Line	
A,B W1	Start-A-B-Finish
A,B W2	Start-A-B-A-B-Finish
A,B W3	Start-A-B-A-B-A-B-Finish

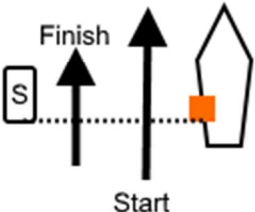

Finish Start

Windward/Leeward Course,
Mid-Course Line

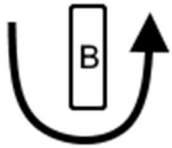

SBYC Wednesday Night Series 2024

Sailing Instructions



Appendix 2: Lake Marks - Map

Mark Map

Red pins are fixed marks with SBYC buoys. The Orange teardrop is an existing red ball near The Harbor docks. Yellow teardrops are “virtual” marks with predefined locations which can be used during regattas with temporary marks. Yellow pins are Rush Creek Yacht Club marks.

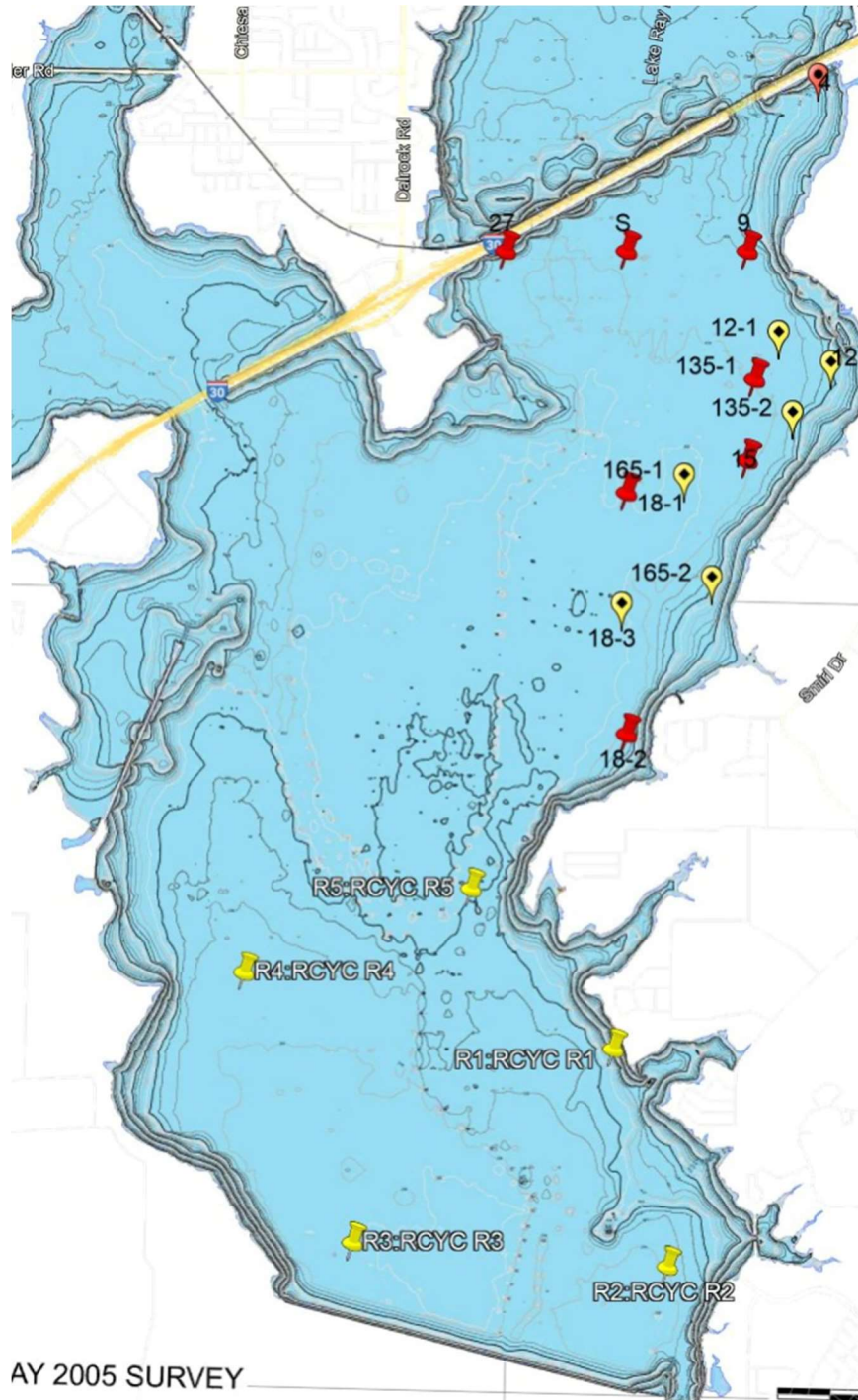

SBYC Wednesday Night Series 2024

Sailing Instructions



Appendix 3: Lake Marks – Locations

From

Mark	Description	Latitude	Longitude	S	4	9	12-1	12-2	135-1	135-2	15	165-2	165-1	18-1	18-3	18-2	27	R1	R2	R3	R4	R5
S	Start(0)	32N 52.688	96W 30.018	-	050	090	120	120	135	135	150	165	165	180	180	180	270	181	178	195	208	194
4	The Harbor(A)	32N 53.377	96W 29.05	230	0	204	189	177	193	184	191	192	199	200	200	200	242	192	188	202	213	204
9	Chandlers-N(B)	32N 52.688	96W 29.423	1.07	0	0.76	1.08	1.19	1.25	1.4	1.59	1.75	1.87	2.34	2.81	1.49	1.49	4.09	4.94	5.18	4.39	3.63
12-1	Chandlers-S 0.75m(C)	32N 52.313	96W 29.245	0.5	0.76	0	0.4	0.82	0.53	0.74	0.87	1.4	1.4	1.12	1.58	2.06	1	3.35	4.22	4.42	3.64	2.88
12-2	Chandlers-S 1.0m(D)	32N 52.188	96W 28.988	300	357	324	300	-	265	217	225	209	233	240	221	210	290	198	191	209	225	215
135-1	Wing 0.75m(E)	32N 52.158	96W 29.387	315	013	357	038	085	-	135	165	190	212	228	209	200	297	192	186	205	221	209
135-2	Heath Inlet	32N 51.981	96W 29.177	0.75	1.25	0.53	0.2	0.34	0	0.25	0.34	0.87	0.51	0.71	1.11	1.56	1.16	2.84	3.7	3.95	3.24	2.41
15	Matria Bay(G)	32N 51.823	96W 29.423	330	011	000	017	045	005	053	-	194	247	255	218	204	311	193	186	207	224	213
165-2	Heath Inlet 1.44m(H)	32N 51.298	96W 29.575	1.44	0.12	0.05	0.15	0.29	0.87	0.76	0.54	-	345	316	254	211	328	193	184	209	231	219
165-1	Heath Inlet 1.0m(I)	32N 51.723	96W 29.71	345	019	014	034	053	032	060	067	165	-	263	206	194	322	188	182	204	222	208
18-1	South 1.0m(K)	32N 51.689	96W 30.018	1	1.87	1.12	0.9	1	0.71	0.76	0.51	0.52	0.28	0.44	0	0.26	0.59	1.07	1.23	2.36	3.24	3.44
18-3	South 1.5m(L)	32N 51.189	96W 30.018	0.00	0.20	0.18	0.30	0.41	0.29	0.42	0.38	0.74	0.26	0.00	-	180	341	182	176	204	227	209
18-2	South 2.0m(M)	32N 50.689	96W 30.018	0.00	0.17	0.14	0.22	0.30	0.20	0.29	0.24	0.31	0.14	0.00	0.00	-	346	182	176	208	238	225
27	Sapphire Bay(N)	32N 52.688	96W 30.618	0.90	0.62	0.90	1.08	1.17	1.20	1.31	1.48	1.42	1.53	1.61	1.66	1	2.06	1.72	1.71	1.89	2.00	1.83
R1	RCYC Club	32N 49.383	96W 30.083	3.31	4.09	3.35	3.02	2.95	2.84	2.71	2.5	1.96	2.26	1.81	1.31	3.34	3.52	-	0	0.93	1.34	1.56
R2	RCYC Heath	32N 48.483	96W 29.817	3.88	0.07	0.04	0.07	0.11	0.06	0.09	0.06	0.04	0.02	0.24	0.24	0.24	0.20	0.28	0.09	0.53	0.84	0.78
R3	RCYC Sunnyside	32N 48.583	96W 31.387	0.15	0.22	0.22	0.26	0.29	0.28	0.27	0.29	0.27	0.29	0.24	0.24	0.24	0.20	0.28	0.09	0.53	0.84	0.78
R4	RCYC Power Plant	32N 49.7	96W 31.9	0.28	0.33	0.35	0.40	0.45	0.41	0.45	0.44	0.51	0.42	0.38	0.47	0.58	0.20	0.28	0.16	1.34	1.31	1.55
R5	RCYC Terry Point	32N 50.05	96W 30.783	3.38	4.39	3.64	3.44	3.49	3.23	3.35	0.33	0.33	0.33	0.39	0.29	0.21	0.29	0.45	0.03	1.39	1.53	1.82
				2.72	3.63	2.88	2.61	2.62	2.41	2.36	2.11	1.61	1.61	1.61	1.61	1.61	1.61	1.61	1.61	1.61	1.61	1.61

To

Note: Mark A is a red, round buoy off of The Harbor docks. Coordinates for Mark A are approximate.

Distances are in nautical miles

See SBYC web page for mark location file for use with GPS.